

SHARP

5合1純蒸氣焗爐 5-IN-1 PURE STEAM OVEN

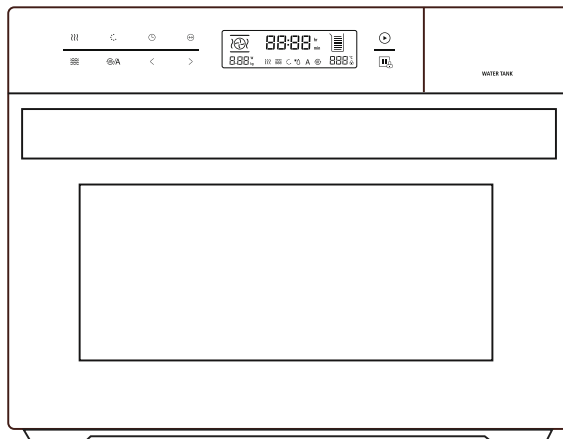

R-1340R

使用說明書 OPERATION MANUAL

使用前，請仔細閱讀說明書並妥善保存。

READ THE MANUAL CAREFULLY BEFORE USING THE APPLIANCE AND KEEP IT PROPERLY FOR FUTURE REFERENCE.

CONTENTS

Contents	E-1	Convection Cooking Mode	E-17
Precautions	E-2	• Convection	E-17
Specifications	E-2	• Convection & Microwave	E-18
Important Safety Instructions	E-3	Grill Cooking Mode	E-19
Cleaning and Care	E-7	• Grill	E-19
Oven and Accessories	E-8	• Grill Fan	E-20
Installation	E-9	• Grill & Microwave	E-21
Before First Use	E-10	• Grill Fan & Microwave	E-22
Control Panel	E-11	Fermentation Mode	E-23
Clock Setting	E-11	Microwave Cooking Mode	E-24
Cooking Chart	E-12	• Microwave Power Chart	E-25
Steam Cooking Mode	E-13	Auto Cooking Mode	E-26
• Steam Instruction	E-13	• Auto Menu Chart	E-27
• Pure Steam	E-14	Preheating Mode	E-30
• Steam & Convection	E-15	Defrost Mode	E-31
• Steam & Microwave	E-16	Descale Mode	E-32
		Child Lock	E-33
		Trouble Shooting	E-34

PRECAUTIONS

Do not use the oven with the door open.

WARNING: If the oven door or door seals are damaged, the oven must not be used until it has been repaired by a qualified technician. If the product is not cleaned regularly, the appliance surface will be degraded to affect the appliance service life and danger may occur.

SPECIFICATIONS

Model: R-1340R			
Rated Voltage	220-230V~50Hz	Rated Input Power (Maximum)	2750W
Rated Input Power (Microwave)	1550W	Oven Capacity	34L
Rated Output Power (Microwave)	900W	Outside Dimensions (W x H x D)	501 x 418 x 526* mm
Rated Output Power (Grill)	1200W	Cavity Dimensions (W x H x D)	405 x 210 x 385 mm
Rated Input Power (Convection)	1750W	Weight	~34kg
Rated Input Power (Steam)	1500W	Color	Red

* Does not include door handle

IMPORTANT SAFETY INSTRUCTIONS

WARNING

To reduce the risk of fire, electric shock or injury to persons. Please follow the precautions and the following safety instructions:

1. **WARNING:** Liquids and other food must not be heated in sealed containers since they are liable to explode.
2. **WARNING:** It is hazardous for anyone except for a qualified technician to disassemble, repair or modify the oven.
3. This appliance cannot be used by children and they should be supervised to ensure that they do not play with the appliance.
4. This appliance cannot be used by persons with reduced physical, sensory or mental capabilities or lack of experience and knowledge, unless this person can use the oven safely under supervision and guidance.
5. Keep the appliance and its cord out of reach of children.
6. Utensils should be checked to ensure that they are suitable for use in each cooking mode.
7. The oven should be cleaned regularly to prevent the air inlet and outlet from being blocked by foreign matter and dust.
8. When heating food in plastic or paper containers, keep an eye on the oven due to the possibility of ignition.
9. If smoke is observed, switch off or unplug the appliance and keep the oven door closed. Steam from the oven may cause burns.
10. Do not overcook food, they may catch fire.
11. Do not use the oven cavity for storage purpose.
12. Remove wire twist-ties and metal handles from paper or plastic containers/ bags before placing them in the oven.

IMPORTANT SAFETY INSTRUCTIONS

13. Install or locate this oven only in accordance with the installation instructions provided.
14. Eggs with shell and whole hard-boiled eggs should not be heated in oven since they may explode.
15. This appliance is for household use only.
16. If the power supply cord is damaged, do not use the product. Please call SHARP service center for repair.
17. Do not store or use this appliance outdoors.
18. Do not put the product at a damp place, e.g. near a gas stove, electrified area or sink.
19. The oven surface, air outlet and oven cavity may become very hot during and after use. Do not touch these parts; otherwise you may be scalded.
20. Do not let cord hang over edge of table or counter.
21. If the product is not cleaned regularly, the appliance surface will be degraded to affect the appliance service life and danger may occur.
22. After you use a milk bottle or heat baby food, you should check the temperature before feeding to avoid hurt.
23. Heating of beverages can result in delayed eruptive boiling, therefore care must be taken when handling the container.
24. **WARNING:** Accessible parts may become hot during use. Children should be kept away.
25. Do not use steam cleaner.
26. The oven door, outer cabinet and oven cavity will become hot during use, please do not touch.

IMPORTANT SAFETY INSTRUCTIONS

27. Use the cooking thermometers to measure the temperature of food.
28. The oven is for household used only. It must not be placed in a cabinet.
29. The oven is used for heating food and beverages. Drying of food or clothing and heating of warming pads, slippers, sponges, damp cloth may lead to the risk of injury or ignition.
30. After cooking and the oven has cooled, remove and empty the water tank, wipe oven cavity with a soft cloth or sponge. Wait a few minutes, empty the drip tray.
31. Do not immerse the appliance in water or other liquid when cleaning.
32. Put a teaspoon in the container when heating beverages. This will ensure that the liquid does not boil suddenly after being removed from the oven cavity.



IMPORTANT SAFETY INSTRUCTIONS

33. **DANGER:** Electric Shock Hazard. Touching the internal components can cause serious personal injury or death. Do not disassemble this appliance.
34. **WARNING:** Do not open the oven with your face close to the oven. Steam from the oven may cause burns.
35. **WARNING:** Electric Shock Hazard. Improper use of the grounding can result in electric shock. Do not plug into an outlet until appliance is properly installed and grounded.
36. The oven must be grounded before use. In case of electric leakage, the ground can provide a current loop to avoid electric shock. The power supply plug must be inserted into a single-phase bipolar socket with grounding.
37. Consult a qualified technician if you do not understand the grounding instructions.

CLEANING AND CARE

Remove the power supply plug.

1. Clean the cavity of the oven with a slightly moist cloth.
2. Clean the accessories in soapy water.
3. The door frame and seal and other parts must be cleaned carefully with a moist cloth when they are dirty.
4. Do not use a corrosive cleaning agent; otherwise it will damage or corrode the product.
5. Place half a lemon in a bowl, add 300ml water and heat on 900W microwave power for 10 minutes. Wipe the oven clean using a soft, dry cloth.

OVEN AND ACCESSORIES

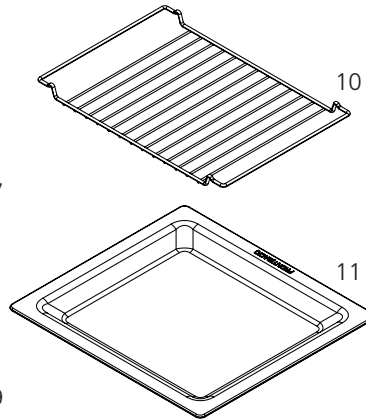
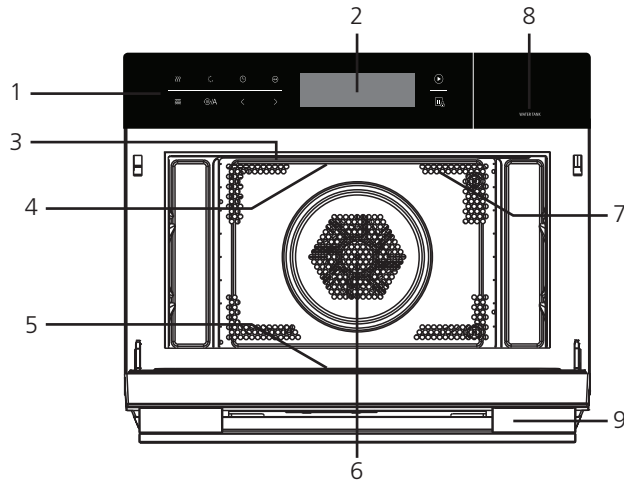

1. Control panel
2. Display
3. Heating tube
4. Oven light
5. Door glass
6. Convection fan
7. Steam inlet and outlet
8. Water tank
9. Drip tray
10. Grill rack
(Do not use when
microwave cooking)
11. Glass tray

INSTALLATION

BEFORE INSTALLATION

Remove all packing materials and accessories. Check the oven for any damage such as broken door. Do not install if oven is damaged.

Do not remove the light brown Mica cover attached to the oven cavity to protect the magnetron.

1. Select a flat surface that provide enough space for good ventilation.

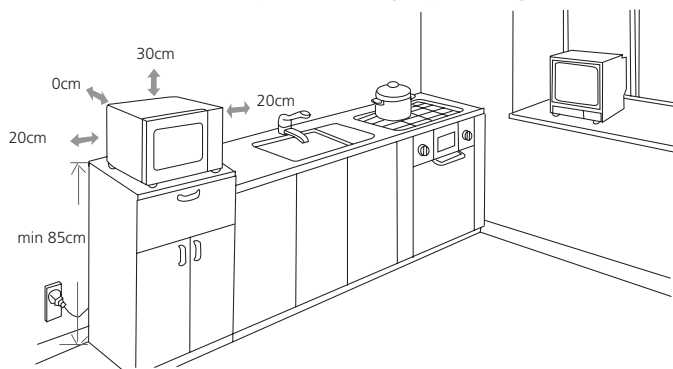







- (a) Place at a position more than 85cm above the ground.
 - (b) Place against the back wall. Reserve a gap not less than 20cm from the right and left wall. And leave at least 30cm space above the oven.
 - (c) Do not remove the legs at the bottom of the oven.
 - (d) Do not block the air inlet and outlet.
 - (e) Place the oven as far away from radios and TV as possible. Operations of oven may cause interference to your radio or TV reception.
2. Plug your oven into a standard household outlet. Be sure the voltage and the frequency is same as rating label.

WARNING: Do not install the oven at a damp place or near heat-producing appliance e.g. near a gas stove, electrified area or sink. The oven surface will become very hot during use. Please do not touch.



BEFORE FIRST USE

INITIAL CLEANING AND HEATING

- Remove all accessories
- Ventilate the room
- Press "  " to choose the convection mode "  " .
- Press "  " to select temperature at 230°C.
- Press "  " and "  " to heat the empty oven for 1 hour.
- Touch "  " to start.
- After finished, wipe the oven cavity with a moist cloth.

CONTROL PANEL

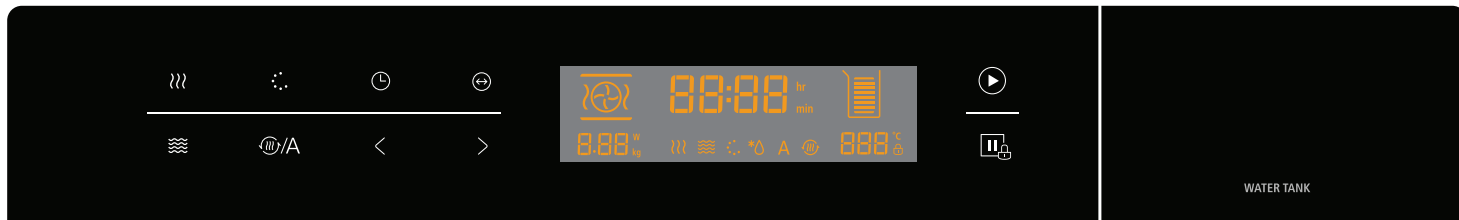

CLOCK SETTING

1. Press " ⌚ " and hold for 3 seconds to set the clock.
2. Press " < " or " > " to set the time (between 00:00 and 23:59).
3. After you have set the time, press " ⌚ " to finish setting.

COOKING CHART

Cooking Mode	Preheat	Temperature / Power	Time Range
Pure Steam	N	50 - 100°C	90 mins
Steam & Convection	N	Steam: L1 - L4 Convection: 180 - 220°C	90 mins
Steam & Microwave	N	Steam: 80 - 100°C Microwave: 100 - 300W	90 mins
Convection	Y*1	50 - 230°C	5 hours
Convection & Microwave	Y*1	Convection: 50 - 230°C Microwave: 100 - 700W	90 mins
Grill	N	1 - 3	90 mins
Grill Fan	Y*1	35 - 180°C	5 hours
Grill & Microwave	N	Grill: 1 - 3 Microwave: 100 - 700W	90 mins
Grill Fan & Microwave	Y	Grill fan: 100 - 180°C Microwave: 100 - 700W	90 mins
Microwave	N	100 - 900W	90 mins*2

*1 Preheat is not available if the temperature is set at 50°C or below

*2 If the microwave power set at 900W, the maximum cooking time is 30 minutes

STEAM COOKING MODE

STEAM INSTRUCTION

1. Before steam cooking:

- Before starting the steam cooking mode, please clean the water tank and fill water.
- Install the drip tray properly.

2. During steam cooking:

During steam cooking mode, if no water in the water tank, abnormal buzzer will ring and the lack of water icon will show on the screen to remind you to refill water. Press "  " after position back the water tank to resume cooking.

3. After steam cooking:

- Remove and empty the water tank.
- The drip tray should be removed and clean on a regular basis.

4. Defect codes

Below defect codes may appear during steam cooking :

E-06: Water tank is not close well, check whether the water tank is install properly.

Note: If the water tank is fully filled and properly installed, but abnormal buzzer ring and the lack of water icon show on the screen, please contact SHARP service center for repair.

STEAM COOKING MODE

PURE STEAM













1. Press " ||| " to enter into the pure steam mode, the default time 10:00 blinks.
2. Press " < " or " > " to select the cooking time. The maximum cooking time is 90 minutes.
3. Press the " ⬅️ " , the default temperature 100°C blinks, then press " < " or " > " to select a temperature (50°C, 60°C, 70°C, 80°C, 85°C, 90°C, 95°C, 100°C).
4. Press " ▶️ " button to start cooking.



If you want to change the setting, press " ⌚ " to enter into time setting mode, or press " ⬅️ " to enter into steam temperature setting mode before cooking.

STEAM COOKING MODE

STEAM & CONVECTION



1. Press "  " 3 times to select steam & convection cooking mode, the default temperature 180°C blinks.
2. Press "  " or "  " to select temperature. (180°C, 190°C, 200°C, 210°C, 220°C)
3. Press "  " the default steam level "L3" flash, then press "  " or "  " to set the steam level [L1 (min), L2, L3, L4 (max)].
4. Press "  " and then press "  " or "  " to set the cooking time. The maximum cooking time is 90 minutes.
5. Press "  " button to start cooking.

If you want to change the setting, press "  " to enter into time setting mode, or press "  " to enter into steam level or temperature setting mode before cooking.

STEAM COOKING MODE

STEAM & MICROWAVE



1. Press " } } } " 2 times to select steam & microwave cooking mode , the default cooking time "10:00" blinks.
2. Press " < " or " > " to select the cooking time. The maximum cooking time is 90 minutes.
3. Press " ↔ ", then press " < " or " > " to set the power (100W, 300W).
4. Press " ↔ ", the default steam temperature 100°C blinks, then press " < " or " > " to select the steam temperature (80°C, 85°C, 90°C, 95°C, 100°C).
5. Press " ▶ " button to start cooking.



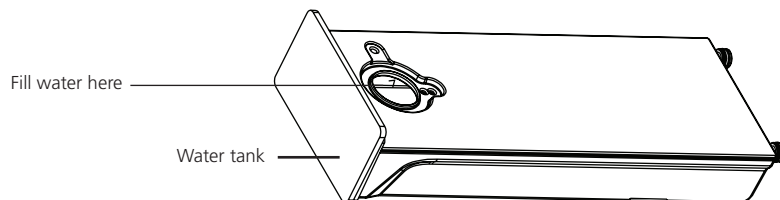



If you want to change the setting, press " ⌚ " to enter into time setting mode, or press " ↔ " to enter into steam temperature or microwave power setting mode before cooking.







CONVECTION COOKING MODE

CONVECTION



1. Press "  " to select convection cooking mode, the default temperature 180°C blinks.
2. Press "  " or "  " to select temperature from 50°C to 230°C. (50°C, 100°C, 105°C, 110°C, 115°C, 120°C, 125°C, 130°C, 135°C, 140°C, 145°C, 150°C, 155°C, 160°C, 165°C, 170°C, 175°C, 180°C, 185°C, 190°C, 195°C, 200°C, 205°C, 210°C, 215°C, 220°C, 225°C, 230°C)
3. Press "  " to select the time setting mode. The default time is 10 minutes. Press "  " or "  " to select the cooking time. The maximum cooking time is 5 hours.
4. Press "  " button to start cooking.





If you want to change the setting, you can press "  " to enter into time setting mode, or press "  " to enter into temperature setting mode before cooking.



* If preheat is needed, press "  /A " after setting, "  " icon will be showed on the screen.
(Preheat is not available if the temperature is set at 50°C or below.)



CONVECTION COOKING MODE

CONVECTION & MICROWAVE



1. Press "  " 3 times to select convection & microwave cooking mode. The default temperature is 180 degrees. The default microwave power is 300W.
2. Press " < " or " > " to select from 50°C to 230°C. (50°C, 100°C, 105°C, 110°C, 115°C, 120°C, 125°C, 130°C, 135°C, 140°C, 145°C, 150°C, 155°C, 160°C, 165°C, 170°C, 175°C, 180°C, 185°C, 190°C, 195°C, 200°C, 205°C, 210°C, 215°C, 220°C, 225°C, 230°C).
3. Press "  ", the default microwave power 300W blinks, then press " < " or " > " to adjust the power. (100W, 300W, 450W, 700W).
4. Press "  " and then press " < " or " > " to set the cooking time. The maximum cooking time is 90 minutes.
5. Press "  " button to start cooking.







If you want to change the setting, you can press "  " to enter into time setting mode, or press "  " to enter into temperature or microwave power setting mode before cooking.

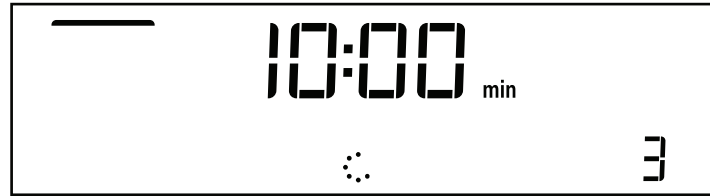

* If preheat is needed, press "  /A " after setting, "  " icon will be showed on the screen.
(Preheat is not available if the temperature is set at 50°C or below.)

GRILL COOKING MODE

GRILL









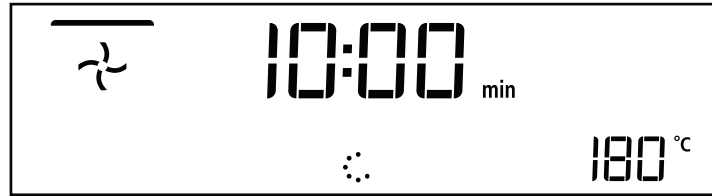

1. Press "  " 2 times to select grill cooking mode. The default grill power is 3 (Level 3). The default cooking time is 10 minutes.
2. Press "  " or "  " to select the grill power level [3 (max), 2, 1 (min)].
3. Press "  " and then press "  " or "  " to set the cooking time. The maximum cooking time is 90 minutes.
4. Press "  " button to start cooking.



If you want to change the setting, you can press "  " to enter into time setting mode, or press "  " to enter into grill power setting mode before cooking.



GRILL COOKING MODE

GRILL FAN



1. Press "  " 4 times to select grill fan cooking mode. The default temperature is 180°C. The default cooking time is 10 minutes.
2. Press "  " or "  " to select temperature from 35°C to 180°C. (35°C, 100°C, 105°C, 110°C, 115°C, 120°C, 125°C, 130°C, 135°C, 140°C, 145°C, 150°C, 155°C, 160°C, 165°C, 170°C, 175°C, 180°C)
3. Press "  " and then press "  " or "  " to set the cooking time. The maximum time is 5 hours.
4. Press "  " button to start cooking.











If you want to change the setting, you can press "  " to enter into time setting mode, or press "  " to enter into temperature setting mode before cooking.



* If preheat is needed, press "  /A " after setting, "  " icon will be showed on the screen.
(Preheat is not available if the temperature is set at 50°C or below.)

GRILL COOKING MODE

GRILL & MICROWAVE







1. Press "  " 5 times to select grill & microwave cooking mode. The default grill power is 3 (level 3). The default microwave power is 300W.
2. Press "  " or "  " to adjust the grill power level [3 (max), 2, 1 (min)].
3. Press "  " , the default power 300W blinks, then press "  " or "  " to adjust the microwave power (100W, 300W, 450W, 700W).
4. Press "  " and then press "  " or "  " to set the cooking time. The maximum cooking time is 90 minutes.
5. Press "  " button to start cooking.



If you want to change the setting, you can press "  " to enter into time setting mode, or press "  " to into grill or microwave power setting mode before cooking.

GRILL COOKING MODE

GRILL FAN & MICROWAVE









1. Press "  " 6 times to select grill fan & microwave cooking mode. The default temperature is 180 degrees. The default microwave power is 300W.
2. Press " < " or " > " to select temperature from 100°C to 180°C. (100°C, 105°C, 110°C, 115°C, 120°C, 125°C, 130°C, 135°C, 140°C, 145°C, 150°C, 155°C, 160°C, 165°C, 170°C, 175°C, 180°C)
3. Press "  ", the default microwave power 300W blinks, then press " < " or " > " to adjust the power. (100W, 300W, 450W, 700W).
4. Press "  " and then press " < " or " > " to set the cooking time. The maximum cooking time is 90 minutes.
5. Press "  " button to start cooking.

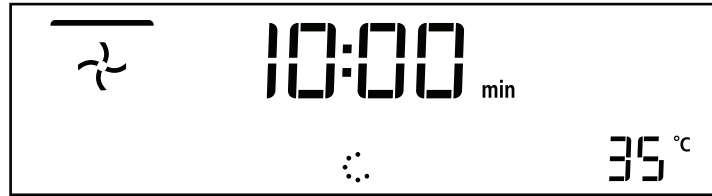

If you want to change the setting, you can press "  " to enter into time setting mode, or press "  " to into temperature or microwave power setting mode before cooking.

* If preheat is needed, press "  /A " after setting, "  " icon will be showed on the screen.

FERMENTATION MODE







1. Press "  " 4 times to select grill fan cooking mode. The default temperature is 180°C. The default cooking time is 10 minutes.
2. Press "  " to select temperature 35°C.
3. Press "  " and then press "  " or "  " to set the cooking time. The maximum cooking time is 5 hours.
4. Press "  " button to start cooking.

If you want to change the setting, you can press "  " to enter into time setting mode, or press "  " to into temperature setting mode before cooking.

MICROWAVE COOKING MODE



1. Press the "  " button to select the microwave cooking mode.
2. Press " < " or " > " to select cooking time, the maximum cooking time is 90 minutes. (If the microwave power set at 900W, the maximum cooking time is 30 minutes.).
3. Press "  ", the default power 900W blinks. Then press " < " or " > " to adjust the power (100W, 300W, 450W, 700W, 900W).
4. Press "  " button to start cooking.

If you want to change the setting, you can press "  " to enter into time setting mode, or press "  " to enter into microwave power setting mode before cooking.

MICROWAVE COOKING MODE

MICROWAVE POWER CHART



Microwave Power	100%	80%	50%	30%	20%
Display	900W	700W	450W	300W	100W

You may choose the power levels according to the type of food. Details refer to the following table.

Power level	Food
900 W	<ul style="list-style-type: none">• Boiling water, reheating• Cooking chicken, fish, vegetables
700 W	<ul style="list-style-type: none">• Reheating• Cooking mushrooms, shellfish• Cooking dishes with eggs or cheese
450 W	<ul style="list-style-type: none">• Cooking rice, soup
300 W	<ul style="list-style-type: none">• Defrosting• Melting chocolate and butter
100 W	<ul style="list-style-type: none">• Defrosting delicate foods• Defrosting irregular shape foods• Softening ice cream

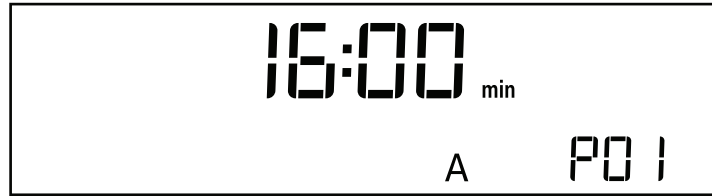
AUTO COOKING MODE



1. Press "  / A " 2 times, the default menu type P01 blinks.
2. Press " < " or " > " to select the menu type, the corresponding cooking time will be changed at the same time.
3. Press "  " and then press " < " or " > " to adjust the weight. The corresponding cooking time will be changed.
4. Press "  " button to start cooking.

AUTO COOKING MODE

AUTO MENU CHART

AUTO-MENU	DISPLAY	WEIGHT (g)	POWER
Carrots (Cook)	P01	-	Steam 100°C
Carrots (Fast Cook)	P02	200	Steam 100°C Microwave 300W
		500	
		1000	
Vegetable (Cook)	P03	-	Steam 100°C
Broccoli (Cook)	P04	-	Steam 100°C
Broccoli (Fast Cook)	P05	200	Steam 100°C Microwave 300W
		500	
		1000	
Potato (Cook)	P06	-	Steam 100°C
Potato (Fast Cook)	P07	200	Steam 100°C Microwave 300W
		500	
		1000	
Frozen Vegetable (Cook)	P08	-	Steam 100°C
Frozen Vegetable (Fast Cook)	P09	200	Steam 100°C Microwave 300W
		500	
		1000	

AUTO COOKING MODE

AUTO MENU CHART

AUTO-MENU	DISPLAY	WEIGHT (g)	POWER
Fish (Steam)	P10	-	Steam 100°C
Fish (BBQ)	P11	-	Preheat Convection 200°C Steam L1
Pizza (Fresh)	P12	-	Preheat Convection 230°C
Pizza (Frozen)	P13	-	Convection 230°C Microwave 450W
Toast (Light)	P14	-	Preheat Convection 230°C
Toast (Dark)	P15	-	Preheat Convection 230°C
Roast Beef (Cook)	P16	-	Convection 200°C Steam L1
Whole Chicken (Cook)	P17	-	Preheat Convection 180°C Steam L3
Whole Chicken (Fast Cook)	P18	-	Convection 220°C Microwave 100W





AUTO COOKING MODE

AUTO MENU CHART

AUTO-MENU	DISPLAY	WEIGHT (g)	POWER
Lasagna (Cook)	P19	800	Convection 200°C Steam L1
Lasagna (Fast Cook)	P20	800	Convection 220°C Microwave 300W
Pork Knuckle (Cook)	P21	-	Steam 100°C Convection 230°C
Chocolate (Melt)	P22	50	Microwave 300W
		100	
		150	
Butter (Melt)	P23	50	Microwave 700W
		100	
		150	

PREHEATING MODE



1. If you want to preheat the food before grill or convection, press "/A" after setting. " " icon will be showed on the screen.
2. Press " " button to start preheating. After preheating, you will hear three beeps. You can stop preheating by opening the oven door or pressing the " " button.

Note:

- The preheating function only works if you have already chosen convection or grill fan modes.
- During preheating, don't put the food in the oven.
- Preheating is not available if the temperature is set at 50°C or below.

DEFROST MODE

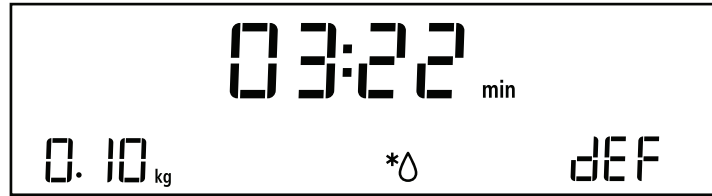

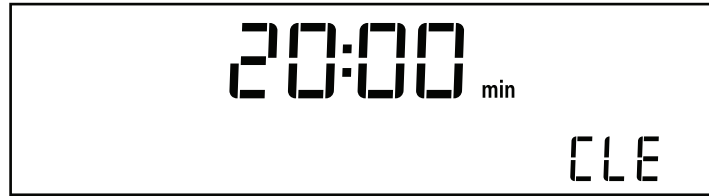

1. Press " / A " button to select defrost mode.
2. Press " " button and then press " < " or " > " to adjust the defrost weight, the corresponding cooking time will be changed.
3. Press " " button to start cooking.

DESCALE MODE







Scale may form in the water circuit inside the oven during steam generation, which could cause the oven malfunction. It is necessary to carry out descale mode when steam program run for 20 hours cumulatively.

1. Fill 1000ml of fresh water and add 1 tablespoon pure citric acid into the water tank.
2. Install the water tank properly.
3. Press "  /A " 3 times, "CLE" and the default time "20:00" show up.
4. Press "  " to start the program.
5. When the program is ended and the oven has cooled, take out and rinse the water tank.
6. Repeat step 3 to 6 with fresh water to finish the descaling process.

Note: The descaling process shall not be shut down. If the descaling process shut down before finish, the program must be started from step 3.

CHILD LOCK

Lock: Press "" for 3 seconds, you will hear a long "beep" and "" icon will be showed on screen.

Unlock : Press "" for 3 seconds, you will hear a long "beep", the lock is released, and "" icon will disappear.

TROUBLE SHOOTING

Trouble	Possible Cause	Remedy
When using the oven for the first time. It may smoke or smell	-	See E-7 for cleaning instruction before the first use.
Dim oven light	-	Normal situation during low power microwave cooking.
Steam come out of the air ventilation	-	Normal situation during steam cooking.
Water in the oven	Steam is generated during steam cooking mode.	Wipe with a dry cloth.
Oven cannot be started	1. Power plug is not plugged in tightly.	Unplug. Then plug again after 10 seconds.
	2. Fuse blown or circuit board is damaged.	Contact SHARP service center for repair.
	3. Trouble with outlet.	Close the door again.
	4. Door is not closed properly.	Close the door again.
Glass tray makes noise when microwave oven is used	Oil and food splashes on the glass and oven wall.	Clean the oven on a regular basis.



According to Waste of Electrical and Electronic Equipment (WEEE) directive, WEEE should be separately collected and treated. If at any time in future you need to dispose of this product, please do NOT dispose of this product with household waste. Please send this product to WEEE collecting points where available.

目錄

目錄	C-1	烤焗烹調模式	C-17
注意事項	C-2	· 烤焗	C-17
規格	C-2	· 烤焗及微波	C-18
重要安全須知	C-3	燒烤烹調模式	C-19
清潔及注意事項	C-7	· 燒烤	C-19
焗爐及配件	C-8	· 燒烤(熱風對流)	C-20
安裝須知	C-9	· 燒烤及微波	C-21
首次使用前	C-10	· 燒烤(熱風對流)及微波	C-22
操控面板	C-11	發酵模式	C-23
時鐘設定	C-11	微波烹調模式	C-24
烹調功能表	C-12	· 微波火力強度表	C-25
蒸煮烹調模式	C-13	自動烹調模式	C-26
· 蒸煮操作須知	C-13	· 自動烹調功能表	C-27
· 純蒸	C-14	預熱模式	C-30
· 蒸煮及烤焗	C-15	解凍模式	C-31
· 蒸煮及微波	C-16	除垢模式	C-32
		兒童安全鎖	C-33
		故障排解說明	C-34

注意事項

切勿在爐門打開時使用蒸爐。

警告:如爐門打開或密封襯墊受損,必須經由合資格技師修理妥當之後方可使用。如產品缺乏定期清潔,其表面可能受到侵蝕,因而影響產品的使用壽命甚至影響產品使用的安全性。

規格

型號: R-1340R			
交流電壓	220-230V~50Hz	最大電力消耗	2750W
電力消耗(微波)	1550W	容量	34公升
輸出功率(微波)	900W	外部尺寸 (W x H x D)	501 x 418 x 526* mm
輸出功率(燒烤)	1200W	爐腔尺寸 (W x H x D)	405 x 210 x 385 mm
電力消耗(烤焗)	1750W	重量	約34公斤
電力消耗(蒸煮)	1500W	顏色	紅色

* 不包括門柄

重要安全須知

警告

為減低因使用產品導致失火、觸電或傷人之風險，請遵照注意事項及下列安全須知：

1. **警告：**液體及其他食物必不可於密封容器內加熱，否則可能造成爆炸。
2. **警告：**除合資格技師外，任何其他人如拆除、維修或調校蒸爐均可構成危險。
3. 本產品設計並非讓兒童使用，請看管兒童並確保他們不可以蒸爐嬉戲或視之為玩具。
4. 本產品並非為身體、感官或心理有缺憾，或缺乏相關經驗或知識的人士而設計，除非他們受到負責其安全的人監督，或已接受其操作指示的情況下使用。
5. 切勿讓兒童觸及本產品及其電線。
6. 將器皿放入本產品進行烹調前，請檢查器皿以確定適用於相關的烹調模式。
7. 請經常清潔蒸爐以保持吸氣口及排氣口暢通，免受外物及塵垢阻塞。
8. 當使用塑膠或紙類容器盛載食物烹調時，由於二者屬易燃性質，請多留意爐內情況。
9. 如發現有煙冒出，請關掉蒸爐或拔除電源，並保持爐門關閉，否則從爐內湧出的蒸氣可導致灼傷。
10. 切勿將食物弄至過熱，否則可能導致食物著火。
11. 請勿將爐腔用作儲物用途。
12. 將以紙或塑膠類容器盛載的食物放入蒸爐前，請移除包裝上的金屬線圈及手把。

重要安全須知

13. 請遵照安裝指示安裝及放置蒸爐。
14. 切勿使用蒸爐將連殼生雞蛋及連殼熟雞蛋加熱，否則可能導致爆炸。
15. 本產品設計僅適用於家居環境。
16. 如電源線受損，請勿使用本產品，並應聯絡 SHARP 服務中心安排維修。
17. 切勿於戶外儲放或使用蒸爐。
18. 切勿將本產品放置於濕度高的地方，例如氣體煮食爐旁邊、通電位置或洗手盆。
19. 當蒸爐在使用期間或之後，蒸爐表面、排氣口和爐腔的溫度將十分高。故切勿摸觸上述位置以免造成燙傷。
20. 請勿讓電源線懸掛在桌子或枱面邊緣。
21. 如產品缺乏定期清潔，其表面可能受到侵蝕，因而影響產品的使用壽命甚至影響產品使用的安全性。
22. 當使用蒸爐加熱奶瓶或嬰兒食物時，應先測試食物溫度方行餵食，以免造成燙傷。
23. 使用本產品加熱飲料有可能導致延後爆濺，因此在拿取容器須特別小心。
24. 警告：當產品進行加熱操作時，產品的可接觸部份溫度將十分高，因此切勿讓兒童接近。
25. 切勿使用蒸氣清潔機。
26. 當產品進行加熱操作時，爐門、外箱和爐腔的溫度將十分高，請切勿觸摸。

重要安全須知

27. 請使用食物溫度計量度食物溫度。
28. 本產品設計僅適用於家居環境。切勿將產品放置於廚櫃內。
29. 蒸爐只可用作加熱食物和飲料，請勿用作烘乾食物或衣服、加熱暖包、拖鞋、海綿、濕布，否則可造成傷害或起火。
30. 當完成烹調並待蒸爐冷卻後，請清空儲水箱，並利用軟布或海綿抹淨爐腔。待數分鐘後，清空滴水托盤。
31. 當清潔本產品時，切勿將產品浸入水或其他液體當中。
32. 當加熱飲料時，可在盛載容器內放入一支匙羹，這樣可確保從爐腔取出盛器後，飲料不會突然爆濺。

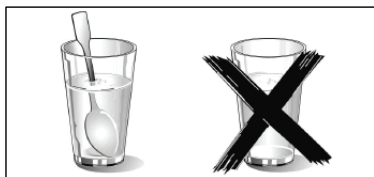

重要安全須知

33. **危險**：觸電危險：接觸內部零件可導致嚴重受傷或死亡，切勿拆除本產品。
34. **警告**：慎防：打開爐門時，勿將臉部貼近蒸爐，否則爐內湧出的蒸氣或可導致燙傷。
35. **警告**：觸電危險：如不適當地連接本產品到標準接地家居電源插座，或將造成觸電。如產品未正確安裝或連接到標準接地家居電源插座，切勿將插頭連接到電源插座。
36. 首次使用蒸爐前，必須連接本產品到標準接地家居電源插座。一旦遇有漏電情況，標準接地設計可提供一組迴路以避免漏電發生。本產品之電源線插頭必須連接到標準接地雙極單相電源插座。
37. 如閣下不清楚電源接地的指示，請向合資格技師查詢。

清潔及注意事項

卸下電源插頭。

1. 請用微濕的毛巾清潔爐腔。
2. 請用混入梘液的水清潔配件。
3. 如爐門門框、密封襯墊及其他部份沾上污垢，可用濕布小心清潔。
4. 切勿使用腐蝕性的清潔劑，否則將對本產品造成損壞或損蝕。
5. 先將半個檸檬放入一個碗內，並注入 300 毫升清水，再放入爐內以 900W 的微波強度加熱 10 分鐘，然後便可使用柔的乾布抹淨爐腔。

焗爐及配件

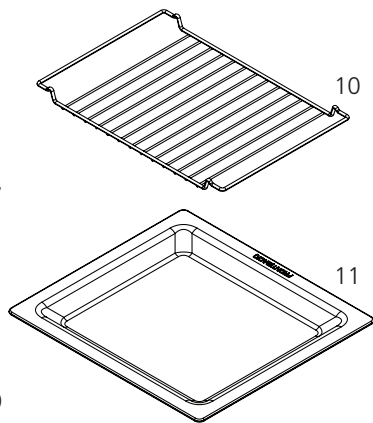
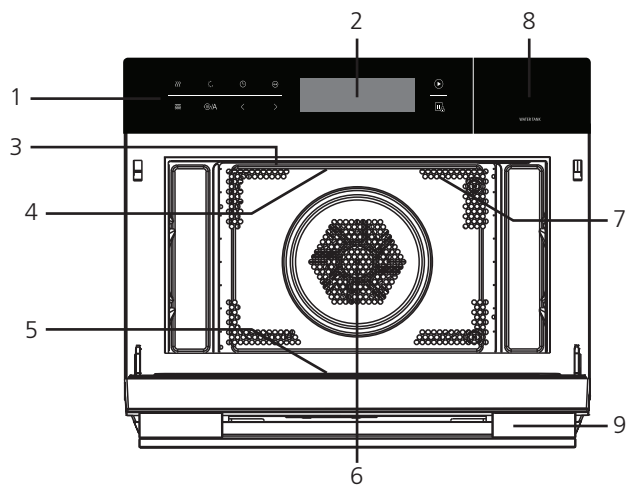

1. 控制面板
2. 顯示屏
3. 發熱管
4. 照明燈
5. 爐門玻璃
6. 對流風扇
7. 蒸氣吸氣口及排氣口
8. 儲水箱
9. 滴水托盤
10. 燒烤網架
(切勿於微波烹調時使用)
11. 玻璃盤

安裝須知

安裝前

先移除所有包裝物料並取出配件。仔細檢查蒸爐是否有任何損壞跡象，例如爐門是否受損。蒸爐如有任何損壞，切勿進行安裝。

切勿移除於爐腔內壁用作保護磁控管的淺啡色雲母表層。

1. 選擇一處可提供足夠空間確保空氣流通的平面。

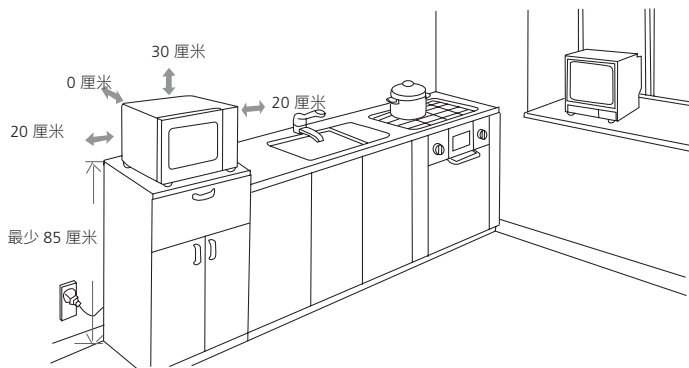

- (a) 應放置於距離地面超過85厘米的位置。
- (b) 置於靠牆位置，並讓爐箱兩側與牆身保持不少於20厘米的空間，而爐上方則應保持最少30厘米的空間。
- (c) 切勿除去爐底部的爐腳。
- (d) 切勿阻礙吸氣及排氣口。
- (e) 請將蒸爐放置於盡可能遠離收音機和電視的位置，因為蒸氣焗爐的操作或會影響電台或電視訊號的接收。





2. 將蒸氣焗爐的插頭連接到標準的家居電源插座，連接時請確認電壓與產品標籤所示一致。

警告：切勿把蒸爐放置在潮濕的地方、接近會產生熱力的電器（如氣體煮食爐）、通電位置或洗手盆。當蒸爐正在使用期間，爐箱表面溫度將十分高，請切勿觸摸。



首次使用前





首次清潔及加熱

- 移除所有配件
- 保持房間空氣流通
- 按 “” 鍵選擇烤焗模式 “” 鍵選擇溫度為 230°C。
- 按 “” 和 “” 鍵將空置的爐設定加熱 1 小時。
- 按 “” 鍵開始操作。
- 操作結束後，用濕布抹淨爐腔。

操控面板



時鐘設定

1. 持續按下 “” 鍵 3 秒鐘以設定時鐘。
2. 按 “” 或 “” 鍵設定時間 (範圍由 00:00 至 23:59)。
3. 當完成設定時間後, 按 “” 鍵結束設定。

烹調功能表

烹調模式	預熱	溫度/火力	烹調時間
純蒸	-	50 - 100°C	90 分鐘
蒸煮及烤焗	-	蒸煮: L1 -L4 烤焗: 180 - 220°C	90 分鐘
蒸煮及微波	-	蒸煮: 80 - 100°C 微波: 100 - 300W	90 分鐘
烤焗	可以*1	50 - 230°C	5 小時
烤焗及微波	可以*1	烤焗: 50 - 230°C 微波: 100 - 700W	90 分鐘
燒烤	-	1 - 3	90 分鐘
燒烤(熱風對流)	可以*1	35 - 180°C	5 小時
燒烤及微波	-	燒烤: 1 - 3 微波: 100 - 700W	90 分鐘
燒烤(熱風對流)及微波	可以	燒烤 (熱風對流): 100 - 180°C 微波: 100 - 700W	90 分鐘
微波	-	100 - 900W	90 分鐘*2

*1 如烹調溫度設定為 50°C 或以下, 預熱功能將無法操作。

*2 如微波火力設定為 900w, 烹調時間最長可設定為 30 分鐘。

蒸煮烹調模式

蒸煮操作須知

1. 蒸煮烹調之前：

- 在進行蒸煮烹調之前，先清洗儲水箱並將水注入。
- 妥善安裝滴水托盤。

2. 蒸煮烹調期間：

當蒸煮烹調進行期間遇上儲水箱沒有水，提示聲將響起，同時顯示屏上會顯示水份不足的圖案，以提醒閣下將水再注入儲水箱。當儲水箱儲水量回復正常後，按 “▶” 鍵恢復烹調操作。

3. 完成蒸煮烹調後：

- 移除儲水箱並清空爐內水份。
- 請定期取出滴水托盤進行清潔。

4. 故障代號：

當進行蒸煮期間，或可能出現下列故障代號：

E-06: 儲水箱未妥善關閉，請檢查儲水箱安裝是否正確。

注意：如儲水箱未注滿或未適當安裝，提示聲將響起，同時顯示屏上會顯示水份不足的圖案。請聯絡 SHARP 服務中心安排維修。

蒸煮烹調模式

純蒸













1. 按 “} } } ” 鍵進入純蒸模式，預設烹調時間顯示為 10:00 (閃動)。
2. 按 “ < ” 或 “ > ” 鍵設定時間，最長為 90 分鐘。
3. 按 “ ↔ ” 鍵，顯示屏上預設溫度顯示為 100°C (閃動)，這時可按 “ < ” 或 “ > ” 鍵設定溫度 (可選擇 50°C、60°C、70°C、80°C、85°C、90°C、95°C 和 100°C)。
4. 按 “ ▶ ” 鍵開始烹調。

如需更改已選設定，可於烹調操作開始之前按 “ ⌚ ” 進入時間設定模式，或按 “ ↔ ” 進入蒸煮溫度設定模式。

蒸煮烹調模式

蒸煮及烤焗



1. 按 “” 鍵 3 次選擇蒸煮及烤焗烹調模式，預設烹調溫度顯示為 180°C (閃動)。
2. 按 “” 或 “” 鍵設定溫度 (可選擇 180°C、190°C、200°C、210°C、220°C)。
3. 按 “” 鍵，預設蒸煮火力顯示為 L3 (閃動)，這時可按 “” 或 “” 鍵設定蒸煮火力 [L1 (最小)、L2、L3、L4 (最大)]。
4. 按 “” 鍵選擇時間設定模式，按 “” 或 “” 鍵設定烹調時間，最長為 90 分鐘。
5. 按 “” 鍵開始烹調。

如需更改已選設定，可於烹調操作開始之前按 “” 進入時間設定模式，或按 “” 進入蒸煮火力或溫度設定模式。

蒸煮烹調模式

蒸煮及微波



1. 按 " } } } " 鍵 2 次選擇蒸煮及微波烹調模式，預設烹調時間顯示為 10:00 (閃動)。
2. 按 " < " 或 " > " 鍵設定烹調時間，最長為 90 分鐘。
3. 按 " ↔ " 鍵，然後按 " < " 或 " > " 鍵設定火力 (可選擇 100W 或 300W)。
4. 按 " ↔ " 鍵，預設蒸煮溫度為 100°C 的顯示會閃動，按 " < " 或 " > " 鍵設定蒸煮溫度 (可選擇 80°C、85°C、90°C、95°C 和 100°C)。
5. 按 " ▶ " 鍵開始烹調。

如需更改已選設定，可於烹調操作開始之前按 " ⌚ " 進入時間設定模式，或按 " ↔ " 進入蒸煮溫度或微波火力設定模式。

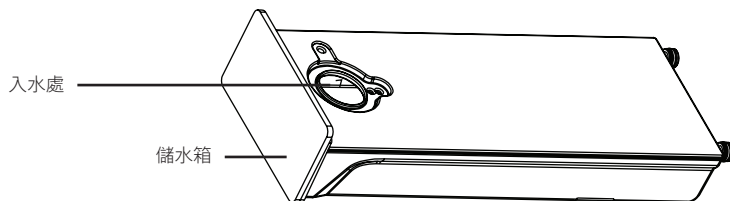



烤焗烹調模式

烤焗



1. 按 “ ” 鍵選擇烤焗烹調模式，預設烹調溫度顯示為 180°C (閃動)。
2. 按 “ ” 或 “ ” 鍵設定溫度，範圍由 50°C 至 230°C (可選擇 50°C、100°C、105°C、110°C、115°C、120°C、125°C、130°C、135°C、140°C、145°C、150°C、155°C、160°C、165°C、170°C、175°C、180°C、185°C、190°C、195°C、200°C、205°C、210°C、215°C、220°C、225°C、230°C)。
3. 按 “ ” 鍵選擇時間設定模式，預設時間顯示為 10:00 (閃動)，這時可按 “ ” 或 “ ” 鍵設定烹調時間，最長為 5 小時。
4. 按 “ ” 鍵開始烹調。









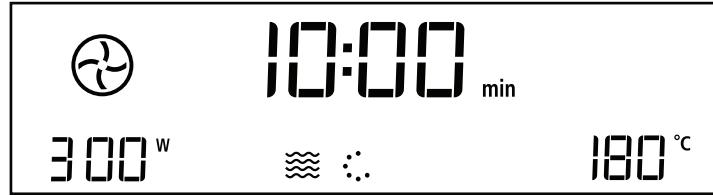

如需更改已選設定，可於烹調操作開始之前按 “ ” 進入時間設定模式，或按 “ ” 進入溫度設定模式。



* 如需預熱，請於選擇烹調模式後按 “/A ” 鍵，顯示屏會顯示 “ ” 的圖案。
(如溫度設定為 50°C 或以下，預熱功能將無法操作。)

烤焗烹調模式

烤焗及微波



1. 按 “” 鍵 3 次選擇烤焗及微波烹調模式，預設烹調溫度為 180°C，預設微波火力為 300W。
2. 按 “” 或 “” 鍵設定溫度，範圍由 50°C 至 230°C（可選擇 50°C、100°C、105°C、110°C、115°C、120°C、125°C、130°C、135°C、140°C、145°C、150°C、155°C、160°C、165°C、170°C、175°C、180°C、185°C、190°C、195°C、200°C、205°C、210°C、215°C、220°C、225°C、230°C）。
3. 按 “” 鍵，預設微波火力顯示為 300W（閃動），這時可按 “” 或 “” 鍵調校火力（可選擇 100W、300W、450W、700W）。
4. 按 “” 鍵，然後按 “” 或 “” 鍵設定烹調時間，最長為 90 分鐘。
5. 按 “” 鍵開始烹調。







如需更改已選設定，可於烹調操作開始之前，按 “” 進入時間設定模式，或按 “” 進入溫度或微波火力設定模式。



* 如需預熱，請於選擇烹調模式後按 “/A” 鍵，顯示屏會顯示 “” 的圖案。
（如溫度設定為 50°C 或以下，預熱功能將無法操作。）

燒烤烹調模式

燒烤









1. 按 “” 鍵 2 次選擇燒烤烹調模式，預設燒烤火力為 3 (第3級)，預設烹調時間為 10 分鐘。
2. 按 “” 或 “” 鍵設定燒烤火力 [3 (最大)、2、1 (最小)]。
3. 按 “” 鍵，然後按 “” 或 “” 鍵設定烹調時間，最長為 90 分鐘。
4. 按 “” 鍵開始烹調。



如需更改已選設定，可於烹調操作開始之前，按 “” 進入時間設定模式，或按 “” 進入燒烤火力設定模式。

燒烤烹調模式

燒烤(熱風對流)



1. 按 “ ” 鍵 4 次選擇燒烤(熱風對流)烹調模式,預設溫度為 180°C,預設烹調時間為 10 分鐘。
2. 按 “ ” 或 “ ” 鍵設定溫度,範圍由 35°C 至 180°C(可選擇 35°C、100°C、105°C、110°C、115°C、120°C、125°C、130°C、135°C、140°C、145°C、150°C、155°C、160°C、165°C、170°C、175°C、180°C)。
3. 按 “ ” 鍵,然後按 “ ” 或 “ ” 鍵設定烹調時間,最長為 5 小時。
4. 按 “ ” 鍵開始烹調。











如需更改已選設定,可於烹調操作開始之前按 “ ” 進入時間設定模式,或按 “ ” 進入溫度設定模式。



* 如需預熱,請於選擇烹調模式後按 “/A” 鍵,顯示屏會顯示 “ ” 的圖案。
(如溫度設定為 50°C 或以下,預熱功能將無法操作。)

燒烤烹調模式

燒烤及微波













1. 按 “” 鍵 5 次選擇燒烤及微波烹調模式，預設燒烤火力為 3 (第3級)，預設微波火力為 300W。
2. 按 “” 或 “” 鍵設定燒烤火力 [3 (最大)、2、1 (最小)]。
3. 按 “” ，預設微波火力顯示為 300W (閃動)，這時可按 “” 或 “” 鍵調校火力 (可選擇 100W、300W、450W、700W)。
4. 按 “” 鍵，然後按 “” 或 “” 鍵設定烹調時間，最長為 90 分鐘。
5. 按 “” 鍵開始烹調。



如需更改已選設定，可於烹調操作開始之前按 “” 進入時間設定模式，或按 “” 進入燒烤或微波火力設定模式。

燒烤烹調模式

燒烤(熱風對流)及微波









1. 按 "  " 鍵 6 次選擇燒烤(熱風對流)及微波烹調模式,預設溫度為 180°C,預設微波火力為 300W。
2. 按 "  " 或 "  " 鍵設定溫度,範圍由 100°C 至 180°C (可選擇 100°C、105°C、110°C、115°C、120°C、125°C、130°C、135°C、140°C、145°C、150°C、155°C、160°C、165°C、170°C、175°C、180°C)
3. 按 "  " ,預設微波火力顯示為 300W 會閃動,這時可按 "  " 或 "  " 鍵調校火力(可選擇 100W、300W、450W、700W)。
4. 按 "  " 鍵,然後按 "  " 或 "  " 鍵設定烹調時間,最長為 90 分鐘。
5. 按 "  " 鍵開始烹調。



如需更改已選設定,可於烹調操作開始之前,按 "  " 進入時間設定模式,或按 "  " 進入溫度或微波火力設定模式。

* 如需預熱,請於選擇烹調模式後按 "  /A " 鍵,顯示屏會顯示 "  " 的圖案。

發酵模式







1. 按 “ ” 鍵 4 次選擇燒烤及熱風烹調模式，預設燒烤火力為 3 (第3級)，預設微波火力為 300W。
2. 按 “ ” 鍵設定溫度至 35°C。
3. 按 “ ” 鍵，然後按 “ ” 或 “ ” 鍵設定烹調時間，最長為 5 小時。
4. 按 “ ” 鍵開始烹調。

如需更改已選設定，可於烹調操作開始之前按 “ ” 進入時間設定模式，或按 “ ” 進入溫度設定模式。

微波烹調模式



1. 按 "  " 鍵選擇微波烹調模式。
2. 按 " < " 或 " > " 鍵設定烹調時間, 最長為 90 分鐘。(如微波火力設定為 900W, 最長烹調時間將為 30 分鐘。)
3. 按 "  " 預設微波火力顯示為 900W (閃動), 這時可按 " < " 或 " > " 鍵調校火力 (可選擇 100W、300W、450W、700W、900W)。
4. 按 "  " 鍵開始烹調。

如需更改已選設定, 可於烹調操作開始之前, 按 "  " 進入時間設定模式, 或按 "  " 進入微波火力設定模式。

微波烹調模式

微波火力功能表

微波火力	100%	80%	50%	30%	20%
顯示	900W	700W	450W	300W	100W

閣下或可按食物種類選擇所需烹調火力，詳情可參閱下表。

火力強度	食物
900 W	<ul style="list-style-type: none">煲水，翻熱煮雞肉、魚、蔬菜
700 W	<ul style="list-style-type: none">翻熱煮菇類，貝殼類煮以雞蛋或芝士製食物
450 W	<ul style="list-style-type: none">煮飯，煲湯
300 W	<ul style="list-style-type: none">解凍溶解朱古力或牛油
100 W	<ul style="list-style-type: none">解凍一般食物解凍形狀不規則食物讓雪糕軟化

自動烹調模式



1. 按 "Ⓜ/A" 鍵 2 次, 預設自動烹調功能選擇為 P01 (閃動)。
2. 按 " < " 或 " > " 鍵選擇自動功能, 顯示屏上的相對烹調時間顯示將隨之變更。
3. 按 " ↔ " , 然後按 " < " 或 " > " 鍵調校食物重量, 顯示屏上的烹調時間將隨之變更。
4. 按 " ▶ " 鍵開始烹調。

自動烹調功能表

自動烹調功能表

自動功能	顯示	重量 (克)	火力
胡蘿蔔 (烹調)	P01	-	純蒸 100°C
胡蘿蔔 (快速烹調)	P02	200	蒸煮 100°C 微波 300W
		500	
		1000	
蔬菜 (烹調)	P03	-	純蒸 100°C
西蘭花 (烹調)	P04	-	純蒸 100°C
西蘭花 (快速烹調)	P05	200	蒸煮 100°C 微波 300W
		500	
		1000	
馬鈴薯 (烹調)	P06	-	純蒸 100°C
馬鈴薯 (快速烹調)	P07	200	蒸煮 100°C 微波 300W
		500	
		1000	
冷藏蔬菜 (烹調)	P08	-	純蒸 100°C
冷藏蔬菜 (快速烹調)	P09	200	蒸煮 100°C 微波 300W
		500	
		1000	

自動烹調功能表

自動烹調功能表

自動功能	顯示	重量(克)	火力
魚(蒸煮)	P10	-	純蒸 100°C
魚(炭燒)	P11	-	預熱 烤焗 200°C 蒸煮 L1
薄餅(新鮮)	P12	-	預熱 烤焗 230°C
薄餅(冷藏)	P13	-	烤焗 230°C 微波 450W
多士(微焦)	P14	-	預熱 烤焗 230°C
多士(焦香)	P15	-	預熱 烤焗 230°C
烤牛肉(烹調)	P16	-	烤焗 200°C 蒸煮 L1
全隻雞(烹調)	P17	-	預熱 烤焗 180°C 蒸煮 L3
全隻雞(快速烹調)	P18	-	烤焗 220°C 微波 100W





自動烹調功能表

自動烹調功能表

自動功能	顯示	重量 (克)	火力
千層麵 (烹調)	P19	800	烤焗 200°C 蒸煮 L1
千層麵 (快速烹調)	P20	800	烤焗 220°C 微波 300W
豬手 (烹調)	P21	-	蒸煮 100°C 烤焗 230°C
朱古力 (軟化)	P22	50	微波 300W
		100	
		150	
牛油 (軟化)	P23	50	微波 700W
		100	
		150	

預熱模式



1. 如閣下需在烤焗或燒烤食物前將食物預熱，請在完成烤焗設定後按 “  /A ” 鍵，顯示屏會顯示 “  ” 的圖案。
2. 按 “  ” 鍵開始預熱。當操作完成後，蒸氣焗爐會發出三下「吽」聲。閣下可打開爐門或按下 “  ” 鍵結束預熱操作。

注意：

- 本預熱功能只在閣下已選定烤焗或燒烤 (熱風對流) 模式後方可進行操作。
- 當預熱操作進行期間，切勿將食物放入爐內。
- 如溫度設定為 50°C 或以下，預熱功能將無法操作。

解凍模式

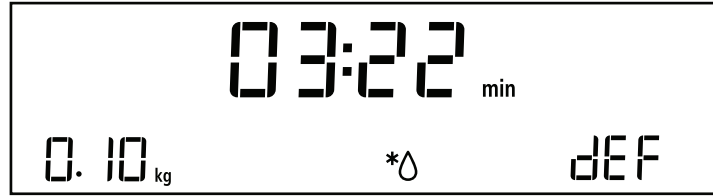



1. 按 " @/A " 鍵選擇解凍模式。
2. 按 " ← " 鍵,然後按 " < " 或 " > " 鍵調校需解凍食物的重量,顯示屏上的相對烹調時間會隨之變更。
3. 按 " ▶ " 鍵開始解凍。

除垢模式







當產生蒸氣時，爐內循環水管或會形成污垢，因而可能導致蒸氣焗爐出現故障。因此，每當使用蒸煮功能累計達 20 小時，便須進行一次除垢模式。

1. 將 1000 毫升水注入儲水箱，並混入 1 茶匙檸檬汁。
2. 將儲水箱裝妥。
3. 按 "  / A " 鍵 3 次，顯示屏會出現預設時間為 20:00 的顯示。
4. 按 "  " 鍵開始操作。
5. 當操作完成，並待蒸氣焗爐完全冷卻後，可拆下儲水箱並加以清洗。
6. 再將清水注入儲水箱，並重複步驟 3 至 6，即完成除垢模式。

注意：除垢模式開始後不應中途停止，否則必須從步驟 3 再開始本模式操作。

兒童安全鎖

上鎖:持續按下  鍵 3 秒, 蒸氣焗爐會發出一下長的「吶」聲, 同時顯示屏將出現  的圖案。

解鎖:持續按下  鍵 3 秒, 蒸氣焗爐會發出一下長的「吶」聲, 同時顯示屏上的  圖案將消失。

故障排解說明

故障情況	可能原因	排解方法
當首次使用蒸爐時，產品或會冒煙或傳出異味	-	首次使用蒸爐前，請依照 C-7 為產品進行清潔。
爐燈變暗	-	當使用低火力進行微波烹調時，會出現這正常情況。
蒸氣從排氣口排出	-	蒸煮操作進行期間，會出現這正常情況。
爐內積水	蒸氣產生時會形成積水。	以乾布清潔。
蒸氣焗爐無法開啟操作	1. 未穩妥插上電源線插頭。	拔除插頭，10 秒後重新插上。
	2. 保險絲溶斷或電路板受損。	聯絡 SHARP 服務中心安排維修。
	3. 家居電插座故障。	聯絡合資格技師安排維修。
	4. 爐門未關妥。	重新將爐門關上。
當使用蒸氣焗爐時，玻璃盤發出噪音	有油或食物濺到玻璃盤或爐壁上。	潔蒸氣焗爐。



根據廢電機電子設備 (Waste Electrical and Electronic Equipment) 指令，屬廢電機電子設備的產品必須分開收集和處理。如閣下將來棄置本產品，切勿將本產品與其他家居廢料一同棄置。閣下應將產品送往最就近的廢電機電子設備回收站處理。

